

BF Hand Pallet Truck

BF2000

- Model BF2000 ,Capacity 2000kg also as Quick Lift Option
- Available in widths 450, 540 & 685 mm. (450mm options shown in Matrix)
- A range of 3 widths, as well as lengths from 600 to 2000 mm means that there should always be a truck to suit your needs.
- The extremely reliable pump unit is fitted with a pressure relief valve to prevent overloading
- 3-Position trigger; Lift, Lower + Neutral
- Comfortable rubber gripped handle.
- The robust chassis is reinforced at the 'A' frame and the legs are strengthened along their length. To reduce maintenance needs, all pivot points are bushed.
- With safety in mind, all machines can be fitted with 3 different braking systems.
- Trucks carry CE mark and comply with all current safety legislation.



Model		BF20 600/ 450	BF20 800/ 450	BF20 900/ 450	BF20 1000/ 450	BF20 1150/ 450	BF20 1220/ 450
Capacity	Kg						
Fork Length (L1)	mm	600	800	900	1000	1150	1220
Fork Spread (W)	mm	450	450	450	450	450	450
Fork Spacing (W1)	mm	130	130	130	130	130	130
Overall Length (L)	mm	1000	1200	1300	1400	1550	1620
Fork Height (h – min)	mm	85					
Fork Height (h – max)	mm	200					
Load Rollers	mm	Ø 80x70 Nylon or Polyurethane					
Steer Wheels	mm	Ø 200x50 Nylon, Polyurethane, Rubber					

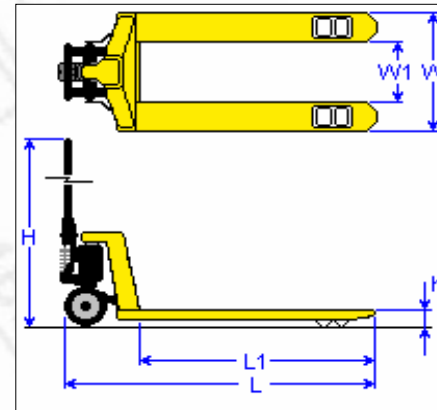

Tandem load rollers are fitted as standard. All trucks can be supplied with single rollers on request



Alternative Steer Wheels



Alternative Load Rollers



Parking Brake Handle

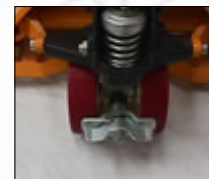

Foot Operated Parking Brake



H.E.S.
HANDLING EQUIPMENT SALES LTD.

Tel: 01525 717174
Fax: 01525 717140

info@hesales.co.uk
www.hesales.co.uk