

F10 / F12 APE Medium Duty Stacker

The F10 and F12APE stackers are medium duty machines for moderate daily use.

- Capacity 1000 or 1200 Kg.
- Lift height 1600, 2500 or 3000 mm.
- Duplex mast configuration allows good sight through the mast uprights.
- Built-in battery charger means that the truck can be charged from any convenient 3-pin socket.
- Ergonomic drive controls.
- Medium duty battery for 3 to 4 hours continuous work even when negotiating inclines.
- Smooth stepless drive controls.
- Trucks carry CE mark and comply will all current safety legislation.
- Comprehensive warranty and superb after sales service provided.

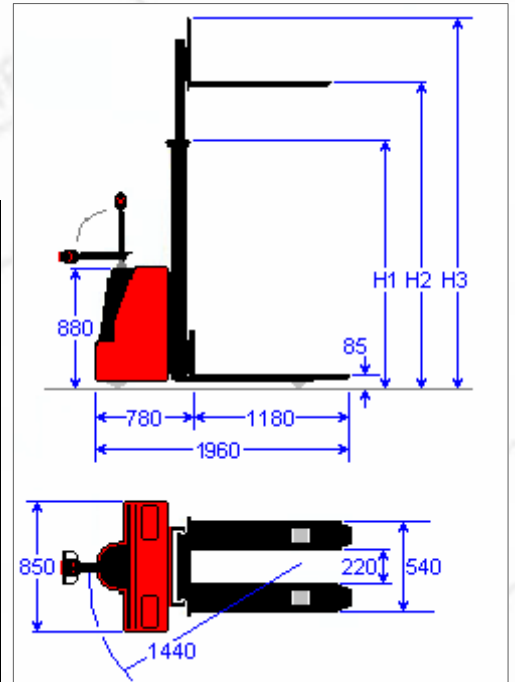

Model		F10APE 1600	F10APE 2500	F10APE 3000	F12APE 1600	F12APE 2500	F12APE 3000
Capacity To 1600 mm	Kg	1000			1200		
Capacity To Full Lift Height (H2)	Kg	1000	1000	700	1200	1200	900
At Load Centre	mm	600					
Wheels		Polyurethane					
Lift Height (H2)	mm	1600	2500	3000	1600	2500	3000
Closed Mast Height (H1)	mm	1990	1750	2000	1990	1750	2000
Open Mast Height (H3)	mm	2125	3120	3620	2125	3120	3620
Mast Configuration		Simplex	Duplex	Duplex	Simplex	Duplex	Duplex
Speeds Laden/unladen	Drive Km/h	4.0 / 5.0					
	Lift cm/sec	5 / 9					
Maximum Gradient Laden / Unladen	%	3 / 5					
Wheels	Load Roller	Ø 80 x 80					
	Rear Wheels	Ø 150 x 40					
	Drive Wheel	Ø 250 x 76					
Brake		Electromagnetic					
Battery	V / Ah	2 x 12v (Series) / 85					
Charger	V / A	24 / 13					
Drive Motor	kW	0.5			0.7		
Truck Weight With Battery	Kg	492	522	552	492	522	552

Options



FEM Class II Carriage



Straddle Legs