

F10 / F12 APL Heavy Duty Stacker

The F10 and F12APL stackers are heavy duty machines, designed for the most demanding applications.

- Capacity 1000 or 1200 Kg.
- Lift height 1600 simplex mast
- Lift height 1600, 2500 or 3000 mm with duplex mast.
- Both mast configurations allow good sight through the mast uprights.
- Built-in battery charger means that the truck can be charged from any convenient 3-pin socket.
- Ergonomic drive controls.
- Heavy duty traction battery for 7 to 8 hours continuous work even when negotiating inclines.
- Many options available.
- Trucks carry CE mark and comply will all current safety legislation.
- Comprehensive warranty and superb after sales service provided.

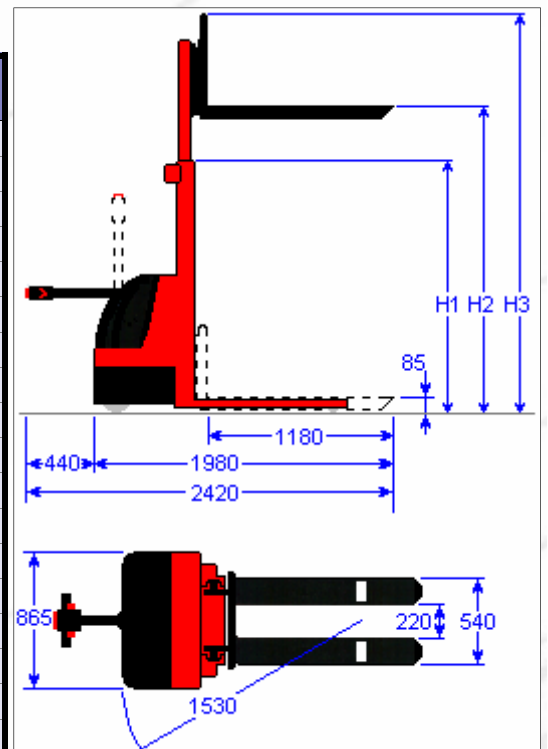

Model		F10APL 1600	F10APL 2500	F10APL 3000	F12APL 1600	F12APL 2500	F12APL 3000
Capacity To 2000 mm	Kg	1000			1200		
Capacity To Full Lift Height (H2)	Kg	1000	800	600	1200	1000	800
At Load Centre	mm	600					
Wheels		Polyurethane					
Lift Height (H2)	mm	1600	2500	3000	1600	2500	3000
Closed Mast Height (H1)	mm	1990	1750	2000	1990	1750	2000
Open Mast Height (H3)	mm	2340	3240	3740	2340	3240	3740
Mast Configuration		Simplex	Duplex	Duplex	Simplex	Duplex	Duplex
Optional Closed Mast Height (H1)	mm	1290	-	-	1290	-	-
Optional Mast Configuration		Duplex	-	-	Duplex	-	-
Maximum Gradient Laden / Unladen	%	5 / 8					
Wheels	Load Roller	Ø 80 x 80					
	Rear Wheels	Ø 150 x 40					
	Drive Wheel	Ø 250 x 76					
Brake		Electromagnetic					
Battery	V / Ah	12 / 240			24 / 240		
Charger	V / A	12 / 30			24 / 30		
Truck Weight With Battery	Kg	640	700	740	720	780	820

Options



FEM Class II Carriage



FEM Class II Carriage



Straddle Legs