



Ergonomic handle ensures the user a relaxed hold.

REM Semi-Powered Stacker

- **Model REM, Capacity 1000Kg**
- **Available in lift heights from 920mm with various heights up to 3300mm**
- **The REM offers high flexibility and efficiency. With one truck goods can be lifted, transported and handled in many different ways**
- **The design puts focus on the safety and ergonomic working conditions of the user - REM can be adjusted to the individual user**
- **Optimum utilisation of the space - REM has a compact construction and is very manoeuvrable**
- **Optimum safety for the user through central location of all control buttons on the handle, transparent and impact-resistant safety screen on the mast and location of parking brake**
- **Strong construction ensures a long operating life and low maintenance costs**
- **Also available with manual lifting (RHM)**

REM



Model		REM						
Capacity	Kg	1000	1000	1000	1000	1000	1000	1000
At Load Centre	mm	575						
Lifting Height (h3)	mm	920	1200	1600	2050	2450	2850	3300
Fork Length	mm	1150						
Overall Height (h1)	mm	1330	1530	1930	1530	1730	1930	2240
Overall Width (b1)	mm	680						932
Fork Span (b5)	mm	480, 520, 560	520, 560					
Length without forks (l2)	mm	590						
Overall Length with 1150 forks	mm	1800			1810			
Lowered Height (h13)	mm	85	90					
Fork Width (e)	mm	163						
Gangway (pallet: 1200 x 800)	mm	2250	2290					
Turning angle of the wheels	degrees	180°						
Pump Motor		1.1 kW 12V						
Lifting Speed		With/without load: 0.05/0.07 m/s						
Lowering speed with/without load		0.12 m/s / 0.04 m/s				0.12 m/s / 0.08 m/s		
Weight without battery	Kg	222	241	251	302	309	322	371

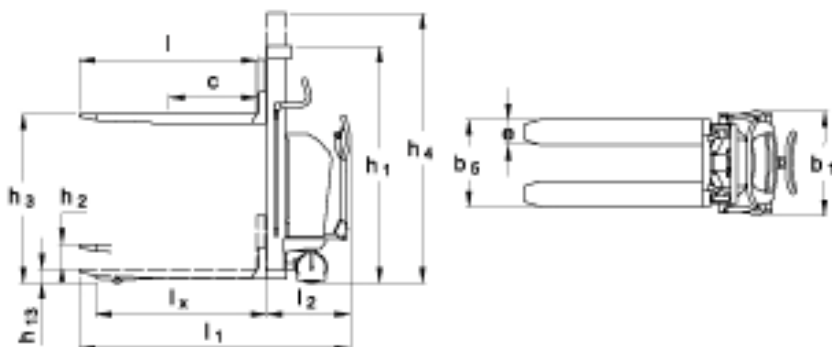

Options

Adjustable forks are available as optional extra in many different lengths and types

Available with side-tilting forks and/or optional extras, e.g drum turner, crane arm, spear, remote control, level control.



H.E.S

HANDLING EQUIPMENT SALES LTD.



Tel: 01525 717174



Fax: 01525 717140

info@hesales.co.uk



www.hesales.co.uk