

RHM Manual Stacker



Ergonomic handle ensures the user a relaxed hold.

- Model RHM, Capacity 1000Kg
- Available in lift heights 920mm + 1650mm
- The RHM offers high flexibility and efficiency. With one truck goods can be lifted, transported and handled in many different ways
- The design puts focus on the safety and ergonomic working conditions of the user - RHM can be adjusted to the individual user
- Optimum utilisation of the space - RHM has a compact construction and is very manoeuvrable
- Optimum safety for the user through central location of all control buttons on the handle, transparent and impact-resistant safety screen on the mast and location of parking brake
- Strong construction ensures a long operating life and low maintenance costs
- Also available with electric lifting (REM)



RHM

Model		RHM	
Capacity	Kg	1000	
At Load Centre	mm	1 / 2	
Lifting Height (h3)	mm	920	1650
Fork Length	mm	1067, 1150	
Overall Height (h1)	mm	1330	
Overall Width (b1)	mm	680	
Fork Span (b5)	mm	Wrap-over forks: 350-560	
Length without forks (l2)	mm	415	
Overall Length with 1150 forks	mm	1675	1685
Lowered Height (h13)	mm	85 (fork span 560) 145 (fork span 350-555)	
Fork Width (e)	mm	163	
Gangway (pallet: 1200 x 800)	mm	2190	
Turning angle of the wheels	degrees	180°	
Lifting Speed		Normal/quick: 8/26 mm per pump	
Lowering speed with/without load		Max. 0.19 m/s / max. 0.07 m/s	
Weight	Kg	219	254

Options

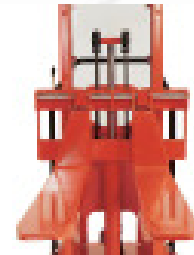

Adjustable forks are available as optional extra in many different lengths and types



Available with side-tilting forks and/or optional extras, e.g drum turner, crane arm, spear, remote control, level control.

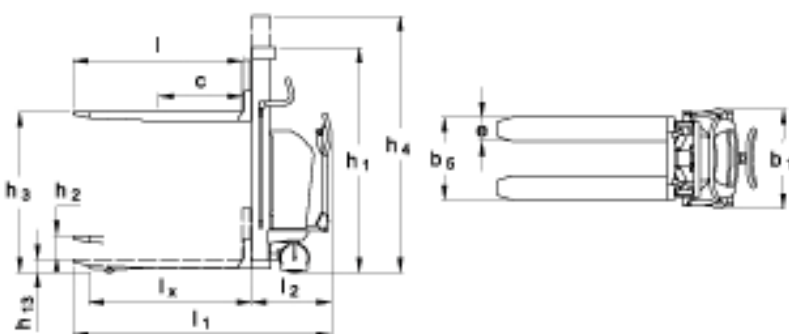



H.E.S.
HANDLING EQUIPMENT SALES LTD.

Tel: 01525 717174
Fax: 01525 717140

info@hesales.co.uk
www.hesales.co.uk